

SUPERFINISH

INNOVATION

μ

modular • flexible • economical • universal

Bandfinisher KG50-DB



Technology-benefits

The optimized surface produces less friction and therefore improves the wearing, the durability, the noise development and the energy expenditure.

This kind of surface improvement is simple – compared to other principles – process-safe and economical.

The Bandfinisher KG50-DB is a double-tape-device which can finish two back-to-back positioned parts at the same time.

The diameters of the parts can be different. Each Finishband can be feded with different speed.

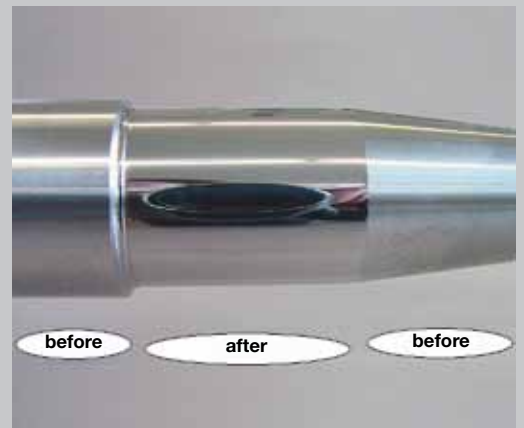

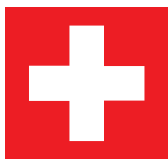

Bandfinisher KG50-DB – Technical datas

Oscillation rate:	300 – 1400 strokes/min.
Oscillation path:	Standard +/- 1 mm optional: +/- 0,5; +/- 1,5; +/- 2 mm
Automated tape feed:	2 x 10 – 100 mm/min.
Pressing-on move:	Standard 40 mm; optional: 70, 100 mm
Pressing-on force:	50 – 300 N (1 – 6 bar); optional: 80 – 480 N
Pressing-on roll:	max. 2 x 25 mm, one-sided arranged bearing
Pressing-on roll hardness:	Standard 65 ShA; optional: 35, 50, 90 ShA
Control voltage:	24 VDC
Weight:	16,5 kg



Adaptors

Elektric:	Connection to Industrial adapter
Needed Controller	maxon DECS50/5; 343253; 3x
Pneumatic:	Connection to valve, 2 x 6 bar

Options

- Clamping cylinder for vertical built in
- div. control sensors

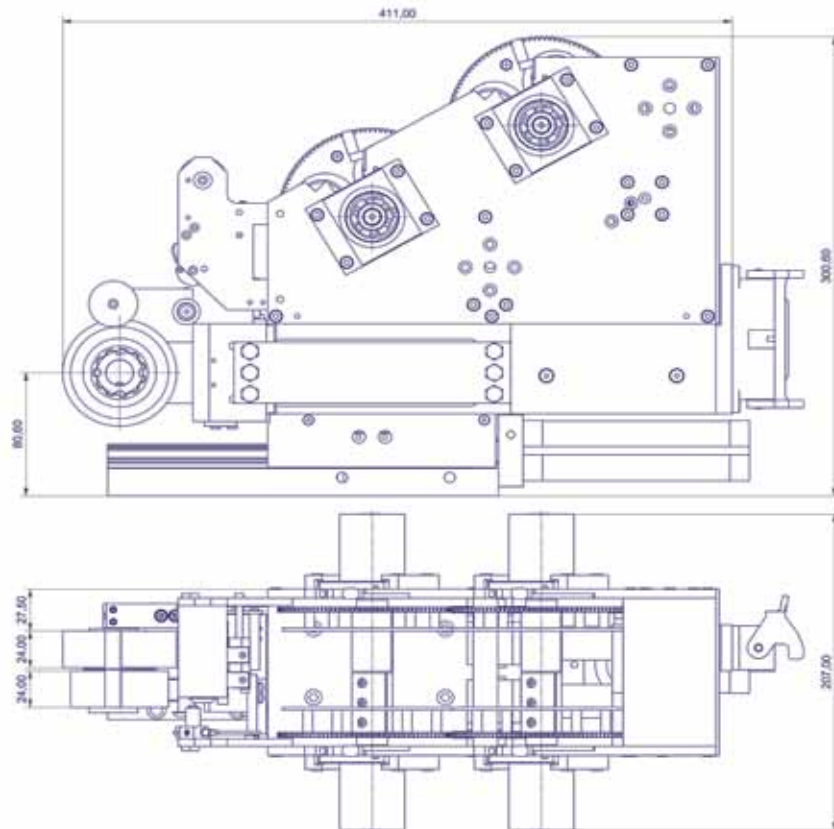
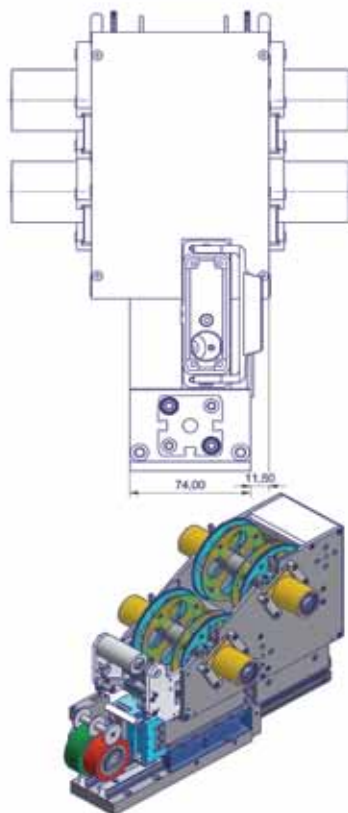

SUPERFINISH – a company of Thielenhaus Technologies



Thielenhaus Technologies GmbH
 Schwesterstrasse 50
 D-42285 Wuppertal
 Phone: +49 (0) 202 - 481-0
 info@thielenhaus.com
 www.thielenhaus.com



Thielenhaus Microfinish Corp.
 42925 W. Nine Mile Road
 Novi, MI 48375, U.S.A.
 Phone: +1 (248) 349 - 9450
 info@thielenhaus.us
 www.thielenhaus.us



Thielenhaus Machinery (Shanghai)
 Jiangtian Dong Lu 92, Building D
 Songjiang Industrial Zone
 201613 Shanghai P.R. China
 Phone: +86 (21) 6775 - 3157
 www.thielenhaus.cn



Superfinish Innovation AG
 St. Gallerstrasse 52
 CH-9548 Matzingen
 Phone: +41 (0)52 376 26 20
 info@superfinish.ch
 www.superfinish.ch